

# ahmarra

## Fire Door Installation & Maintenance Guide

Version 7.3 | 17-04-2026

Please ensure you are referring to the latest version of Ahmarra's Installation Guide by scanning the QR code or visiting;  
<https://ahmarra.co.uk/installation-instructions/>



Timber  
Fire Door  
Manufacture



Enhanced  
Security  
Door



Secured by Design



Official Police Security Initiative



## 1.0 General

Details contained within the Installation Guide refer to the recommended minimum requirements for fire rated finished door leaves and doorsets for installation as supplied by Ahmarra. The specific door weight information can be found on the door label, located on the door. This document also details the minimum number of persons required to lift the door/doorset, and gives the item reference number. Ahmarra products are designed for forklift truck unloading, and are provided in stacks for ease of distribution. Double doorsets are packaged and supplied separately to frames.

The door leaves and doorsets supplied have been tested to the latest edition of BS 476: Part 22, and/or BS EN 1634-1, in addition to being independently certified as achieving fire resistance of up to 30 minutes, 60 minutes or higher as applicable to the fire rating specification, when installed in accordance with the following conditions.

It is the responsibility of the installer to ensure that any packing products such as mineral fibre (rock wool), fire foams and intumescent mastics are checked to ensure they are tested to BS 476: Part 22 or BS EN 1634-1.

The specific test evidence of these products should be checked to ensure they cover your particular gap/wall/frame scenario. The varied use of intumescent mastics, mineral rock fibre, foam or similar products may be used in lieu of/in addition to architrave where such products have a proven performance under fire test conditions with wood doorsets and the guidance from the product manufacturer is adhered to.

Mineral fibre or ceramic fibre packing material must be Euroclass A1 or A2 in accordance with BS EN 13501-1 and be able to withstand temperatures up to 1000°C. Glass fibre material is not allowed.

## 1.1 Storage

Fire door leaves and doorsets are joinery components, and as such, their handling and storage prior to installation should be such that they are protected from rain, sun, and splashing by corrosive or

staining materials, and preferably in a ventilated building. Doors must not be stored on underfloor heating, or leant against walls, as this may cause doors to bow.

### DO NOT;

- Store outside
- Store on door/frame edge
- Store near heaters
- Store in direct sunlight
- Store in damp areas
- Install prior to second fix
- Stack against walls

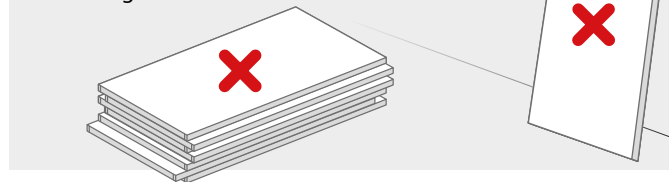

### Recommended Conditions

- Stack doors horizontally
- Separate each door with three timber bearers spaced equally apart to protect the door face
- The widest doors should be at the bottom of the stack and narrowest at the top
- Relative humidity: 40% - 60%
- Temperature range: 12°C to 21°C
- DO NOT STORE OUTSIDE

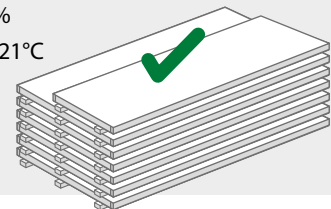

No adhesive tape should be applied to the door faces as this could damage the product's finish. Where doors are subject to large amounts of sunlight, care must be taken as anything placed on the face of veneered doors may leave silhouettes.

## 2.0 Suitability of Structural Openings

It is the main contractor/client's responsibility to ensure that structures to receive fire doorsets comply with National and Local Regulations and that they are suitable for the design performance. For all structural openings built to the manufacturer's specification, standard single door weights of 80kg must be considered.

Please note: Main contractors/clients are recommended to refer to the applicable parts of the latest edition of BS 5588 Fire Precautions in the Design and Construction of Buildings for further guidance.

The fire test/data applicable to doorsets manufactured by Ahmarra anticipates that they will be fitted into block work, brickwork, concrete, timber, or metal stud partitioning, unless the partitioning manufacturer (as applicable) can provide fire test/assessment data to demonstrate that this is not necessary.

Where doorsets are to be fitted into metal stud partitioning, the hollow metal stud at the doorset positions should be filled with a solid timber packer.

The following diagrams indicate acceptable and unacceptable door frame installations.

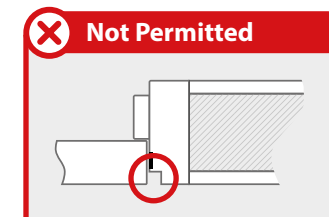
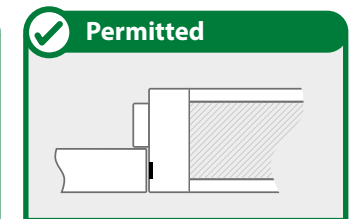
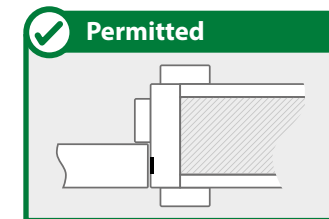

## 2.1 Doorset Installation

Please ensure you have the correct door/doorset in relation to the opening in which it is to be installed. Each product has its own unique reference located on the label. This links with the contract drawings and schedules. This will help match the correct door and frame later, where doors are stored to minimise site damage.

Further details for gap filling between timber door frames and the supporting structure of more than 10mm can be found in section 2.1.1 and the latest edition of the BS 8214:2026 Fire-resisting and smoke controlled doors - Code of Practice.

Doorset frame jambs must be fixed to the supporting structure using fixings at 600mm maximum centres (minimum 5 fixings per jamb) and 150mm from the corners. They must also be of an applicable type for the supporting structure and must penetrate to a minimum depth of 50mm. Ahmarra recommend the use of 100mm screws to meet this requirement.

Whilst it is not deemed necessary to fix the frame head, except for a recommendation to inset at least one fixing in double door applications, it is recommended that packers be inserted between the frame head and the head of the supporting structure.

Before removing any packaging, check the overall dimensions of the doorset will fit the opening its intended for. If this is correct, remove all packaging and take care to retain any loose items. Check that the structural opening is aligned and level before starting installation.

For fire doors, Ahmarra recommends an 8mm maximum undercut from the top of the finished floor to the underside of the door.

Fire and smoke controlled doors = 3mm maximum undercut from the top of the finished floor to the underside of the door. This can be increased by up to 8mm with the use of a suitable threshold sealing system. For smoke controlled doors, it is recommended that contact be made with the local building control or fire officer to seek a solution agreeable to all parties prior to doorset manufacture.

Please note: The lateral force at the bottom hinge position can compress packings and metal studs causing the leading edge to drop. Before installation, please ensure studs are secure and fillings are dry.

To comply with Ahmarra mechanical and fire test certification, you are required to have fixings positioned no more than 150mm from the top and bottom of the door frame jambs, and fixing to the jambs with a maximum spacing between them of 600mm (minimum 5 fixings per jamb). On frames over 1050mm wide, an additional fixing is required to the centre of the frame head.

On heavy doorsets, paired fixings will normally be required, unless specialist fixings are used; of which must be approved by the fixing manufacturer for the door weight. Heavier doors or deeper door linings will require double fixings.

All fixings must be of the appropriate type for the supporting construction and must penetrate to a minimum depth of 50mm. Soft mortar joints are not suitable fixing points, as they will work loose with time. Ahmarra recommend the use of 100mm screws, which is a specific requirement for FD90 and FD120 fire-rated doors.

### Packers

For use of packers, please refer to Q-Mark Certification Bulletin: 052/002 for further advice. If not available, our best practice advice is to use hardwood timber packers. Plastic packers can be used with supporting test evidence in timber doors for the relevant fire rating to either BS 476 Part 22 or BS EN 1634-1.

Fixing should be kept in from partition faces to stop the wall material breaking away; we recommend a minimum of 35mm.

Screws/bolts should have a minimum shank of no less than 5mm, unless fixing manufacturer states that their fixings are suitable for the load to be applied to them. Fixing screws and panel pins are not supplied by Ahmarra.

Failure to follow the fixing recommendations may invalidate any guarantee, affect fire certification or cause the products not to operate as specified.

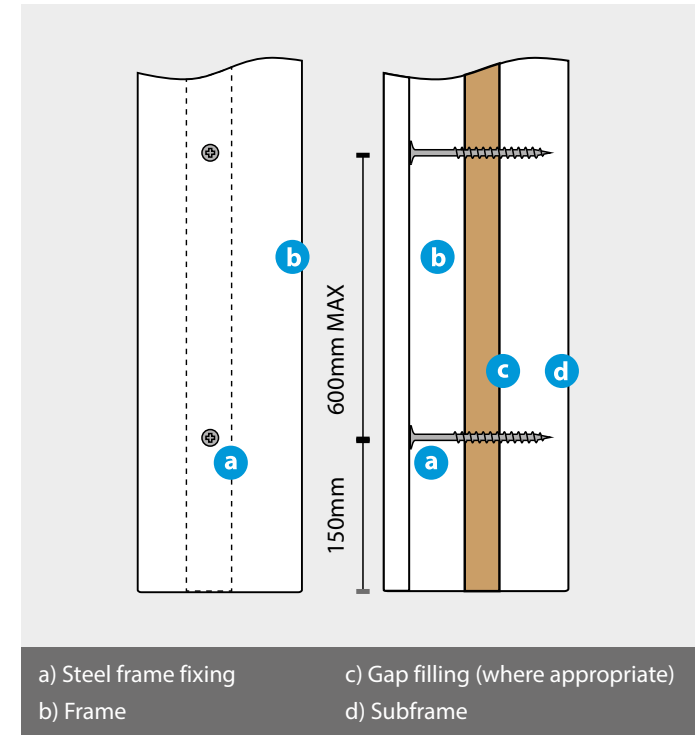

## 2.1.1 Supporting Construction

The supporting construction is unlikely to exhibit significant distortion during fire exposure, e.g. for a masonry wall or non-load bearing timber stud partition.

The supporting construction is the client's responsibility, with any specified fire ratings under separate documentation. Mineral fibre (Rock Wool), intumescent mastics and expanding foam must be tested to BS EN 1366 Part 4, BS EN 1364-1, BS 476 Part 22, BS 476 Part 20 or BS EN 1634-1. Test duration must be at least the same or higher than the integrity period of the fire doorset being fitted.

The specific test evidence of these products should be checked to ensure they cover your particular gap/wall/frame scenario.

Architrave Condition	Additional Protection	Maximum Frame Supporting Construction Gap Width	Suitable for Smoke Control Assemblies	Specific Recommendations or Fire Ratings	Schematic
Architraves to be a minimum 15mm thick constructed from softwood, hardwood or MDF with 15mm overlap on frame and wall	Intumescent mastic applied to fill the gap between the wall and the frame to a minimum depth of 10mm*	Up to 10mm	Yes	FD30 FD60	
No architraves fitted	Mineral rock fibre tightly packed to a depth of the frame making allowance for a 10mm capping, to both face, of intumescent mastic*	Up to 15mm	Yes	FD30 FD60	
Minimum 10mm hardwood quadrant beads tightly fitted between wall and frame	Mineral rock fibre tightly packed for the full depth of the frame capped with intumescent mastic*	Up to 15mm	Yes	FD60 Quadrant bead should be sized appropriate for the wall to frame gap	

# Fire Door Installation

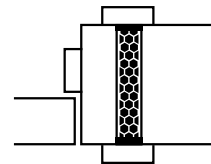
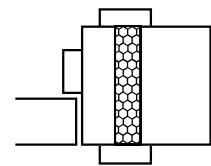
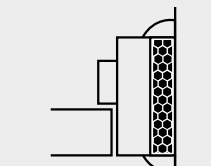
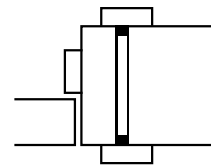
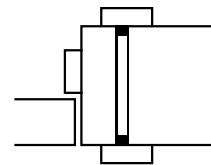
Architrave Condition	Additional Protection	Maximum Frame Supporting Construction Gap Width	Suitable for Smoke Control Assemblies	Specific Recommendations or Fire Ratings	Schematic
Architraves to be a minimum 15mm thick constructed from softwood, hardwood or MDF with a 15mm overlap on frame and wall	Mineral rock fibre tightly packed and capped with intumescent mastic*	Up to 20mm	Yes	FD30 FD60 Rock fibre to be capped with mastic on both sides of the frame with no gaps	
Architraves to be a minimum of 15mm thick constructed from softwood, hardwood or MDF with a 15mm overlap on frame and wall Architraves can be omitted if foam manufacturer's test evidence permits	Expanding foam*	Maximum gaps as per fire foam manufacturer's guidance	Yes	FD30 FD60	
Minimum 10mm hardwood quadrant beads tightly fitted between wall and frame	Mineral rock fibre tightly packed for the full depth of the frame capped with intumescent mastic*	Up to 20mm	Yes	FD30 Quadrant bead should be sized appropriate for the wall to frame gap	
Architraves to be a minimum 18mm thick constructed from hardwood or MDF with an 18mm overlap on frame and wall	<b>Mineral rock fibre:</b> Tightly packed with rock or stone based mineral fibre, capped on both sides with a 10mm depth of acrylic intumescent mastic.	Up to 20mm	Yes	FD90	
Architraves of the same tested material type and dimensions must be applied if included within the evidence used to support the firestopping medium	<b>Expanding foam:</b> Filled to the full depth with fire resisting foam, once cured, a depth of 10mm from each face removed and refilled with intumescent mastic. Products must have been demonstrated (at the required maximum gap dimension) to achieve 90 minutes fire resistance performance behind a timber frame to BS 476: Part 22: 1987 or BS EN 1634-1. Architraves of the same tested material type and dimensions must be applied if included within the evidence used to support the fire stopping medium.	Up to 20mm	Yes	FD90	

Shadow gaps are permitted under certain conditions. Please contact us [sales@ahmarra.co.uk](mailto:sales@ahmarra.co.uk) for further guidance.

\*See section 2.5 for the correct use of additional protection to meet fire resistance requirements. The varied use of intumescent mastics, mineral rock fibre, foam or similar products may be used in lieu of/in addition to architrave where such products have been tested to EN 1366 Part 4, BS 476 Part 22, BS 476 Part 20 or EN 1364-1. Test duration must be at least the same or higher than the integrity period of the fire doorset being fitted and the guidance from the product manufacturer must be adhered to.

## 2.1.2 STS 1009 Acoustic Fitting

STS 1009 Acoustic/smoke perimeter seal.

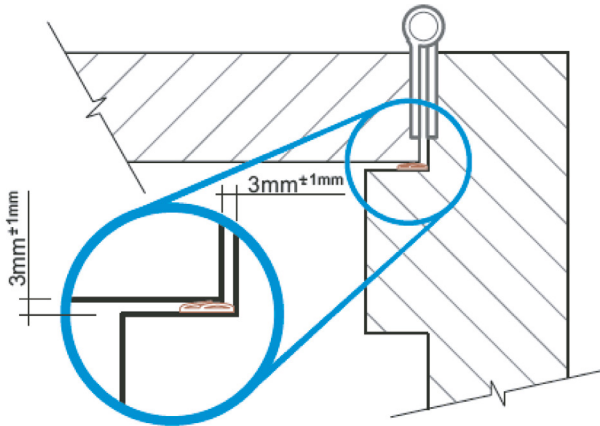

Self-adhesive detail - compression mode

Used in "compression", the ST1009 fits to the active face of the doorstop, and thus has a minimal effect on the force required to close the door. The low co-efficient of the material ensures even less resistance to compression and excellent product recovery when the door is opened.

See additional documentation.

## 2.2 Basic Doorset Installation Steps

Take the frame, place it into the opening and level the head or transom rail. This is done by placing packers under the foot of the jambs or by altering the floor level, whilst bearing in mind the required door undercut needed, as this will lift or lower the door position.

Drill and fix the hanging jamb making sure its plumb and free from bow and twist. Always use packers behind fixings points - you should have an equal number of packers to both sides of the frame.

If necessary, you may wish to put minimal fixings in at this point until the door(s) are re-hung as adjustment might be required.

On doorsets greater than 1050mm (width), a fixing will be required in the centre of the frame head to stop the frame head from sagging.

Re-hang the door in the frame.

Check for a 3mm (+/- 1mm) gap around the door(s) ensuring its flush with the frame. Adjust any packaging as required to achieve this, making sure when done, all fixings are in and have been tightened.

Back fill frame as per previous instructions.

Fix doorstops and architraves as required.

Fix loose doorstops after all adjustments have been made. Fit parallel with the face of the door, making sure the door sits square in its frame and does not protrude beyond the outer edge of the frame, allowing an easy latching action to ensure any seals are in correct contact with the door leaf face.

Doorstops can be pinned or screwed into position at centres to ensure the doorstop is always in full contact with the door frame face.

Where wide doorstops are being used, it may be necessary to apply parallel or staggered fixings to ensure good fit.

Please note: Where lift-off hinges are fitted, architraves greater than 14mm in depth to the head of the frame, must be set back sufficiently to allow the door to lift clear of the hinge pin.

### 2.2.1 Doorstop Seal Arrangements

The seals to the doorstops should make light contact with the door face. If the door face-to-stop gaps are too tight or loose, the door's performance in a fire will be adversely effected.

### 2.2.2 Threshold Seal Arrangements

Drop seals are best suited to solid, smooth floor surfaces to ensure maximum contact. If the door is in an area with uneven surfaces,

or carpeted etc, a threshold will be required. The seal will require adjustment to ensure even light contact with the floor coverings.

### 2.2.3 Extension Linings

Most extension linings fit into a groove on the frame and can be pulled in or out slightly to suit the partition thickness. For performance reasons on some frame types we cannot groove the frame for the extension lining and they will need butt jointing.

The extension lining is normally screw fixed in the same way as the frame and this would be our recommendation, but as this element does not affect the fire rating it can also be bonded in place. Extension linings do not need back filling, therefore, ensure the main frame section is back filled prior to fixing the extension lining in place.

### 2.2.4 Glazing

Apertures cannot be cut into our fire rated doors on site. We strongly recommend that all aperture preparation is carried out in our works and cannot accept responsibility for later problems caused by site cutting of apertures.

### 2.2.5 Door Closers

When fitting concealed door closers, ensure the supplied intumescent/ seal packs are fitted as instructed.

This is critical to achieving the product's fire rating. Without the fitting of the intumescent in the door and frame, certification is invalid. The door and/or frame constructions will need to have been upgraded to receive this type of ironmongery to meet fire certification and mechanical strength data.

## 2.3 Hanging Door Leafs

When hanging door leaves, as supplied by Ahmarra, the frame materials for use with the same should comply with the recommendations to be found by reference to the latest edition of BS 8214. Frame material for FD30 doorsets may be softwood or hardwood of not less than 510 Kg/M3 density at 15% moisture content. Whereas, frame material for FD60 doorsets must be hardwood of not less than 640 Kg/M3 density at 15% moisture content.

Frames must be plumb and square, and assembled with traditional joints with appropriate wood screws (joints maybe glued, and screwed). All joints should be of a tight fit. During the hanging process, an equal gap of 3mm (+/- 1mm) is to be maintained across the head and down both jambs, and up to a maximum of 8mm at the threshold for non-smoke controlled doors.

The gap between the door and frame, and at the meeting stile of double doors, should also not exceed 3mm (+/- 1mm).

The leaf face must be flush to the face of the frame. Never projecting by more than 1mm.

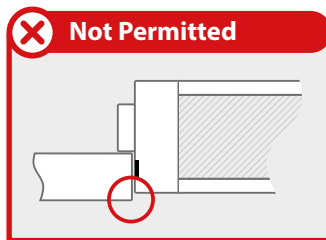
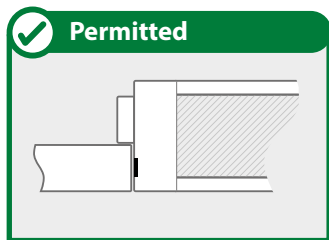

Glazed apertures can potentially be the weakest part of any fire door if glazed incorrectly, and it is for this reason that the cutting on site of apertures for glass is strongly deprecated by Ahmarra, as any non-factory controlled cut-outs and glazing may severely reduce the likelihood of the door maintaining its integrity when exposed to fire, and additionally invalidate the fire door certification.

## 2.4 Over Panels

Over panels must be fixed through the rear of the door frame with steel wood screws passing at least 30mm into the over panel. Fixings are to be spaced at a maximum of 300mm centres, and no more than 100mm from each corner.

## 2.5 Architraves

The utilisation of architraves is commonly used with fire doorsets supplied by Ahmarra and should be of a 15mm minimum thickness. The intention of the architrave is to cover the gap between the frame and the supporting structure, thereby providing for a minimum cover over the edge of the supporting structure and a nominal 15mm cover over the door frame.

The varied use of intumescent mastics, mineral rock fibre, foam or similar products may be used in lieu of/in addition to architrave where such products have been tested to EN 1366 Part 4, BS 476 Part 22, BS 476 Part 20 or EN 1364-1. Test duration must be at least the same or higher than the integrity period of the fire doorset being fitted and the guidance from the product manufacturer must be adhered to.

Please refer to section 2.1.1 for requirements.

## 2.6 BM TRADA Q-Mark

Fire doors save lives and protect property, so it is vital that they are manufactured correctly.

Ahmarra are proud members of the BM TRADA Q-Mark Fire Door Manufacture scheme. BM TRADA are one of the UK's leading providers of independent, third-party certification and are a widely accepted quality standard. The scheme's rigorous audit and testing process ensures doors are consistently manufactured to the approved specification.

Ahmarra's Q-Mark plugs are fitted on the hinge edge side of the door, below the top hinge, as standard. On occasion, it may be necessary to fit the plugs on the top of the door leaf - either at the request of

the customer - or when ironmongery items, such as finger guards, cover the hinge edge.

Q-Mark Fire Door Installers are required to fit the approved 'Gold Plug' as per the scheme's requirements.

Fire Door Installation Q-Mark fire door plugs come in two sections. The outer requires a Ø 9mm hole at 20mm depth to be drilled into the door leaf/frame.

The inner tree then locates into the outer, ensuring that the customer specific certificate numbers at one end remain visible.

All plugs must be spaced a minimum of 25mm distance between each plug and must also be located at least 25mm distance from the hinge or other items of hardware.

**bmtrada**  
Proud to be part of **element**

**Fire Door Certification Scheme**

Outer colour - period of fire integrity.  
Inner/tree colour - status of manufacture.  
Unique certified company's number.

Outer colour - Period of fire integrity (mins)	30 (Yellow)	60 (Blue)	90 (Brown)	120 (Black)
--	-------------	-----------	------------	-------------

**Inner/Tree colour**

Approved door leaf and/or frame* (30min & 60min doors only). Intumescent strips not prepared for or supplied.	Approved factory fitted glazing.
Approved door leaf and/or frame* (30min & 60min doors only). Intumescent strips prepared for and supplied.	Complete certified factory hung doorset.
	Complete certified factory hung doorset with smoke control.
	Certified installation of a complete factory hung doorset.

\*Where the frame and leaf are produced by separate Q-Mark companies, both the frame and leaf must have their own red/green plug.

For details of the scheme and list of certified companies visit [www.bmtrada.com](http://www.bmtrada.com) or call +44 (0) 1494 569960

## 2.7 Hardware

Following the fitting of any ironmongery, it is also important to check that the same move correctly, and particularly that any fitted closers overcome the latch resistance.

Hardware/ironmongery such as hinges, closers, locks, and latches are recommended to be bedded on low-pressure intumescent (interdens), for example;

- Fitted beneath the hinge blades on leaf and frame (60 minute fire rating)
- Encasing latch body (optional)
- Fitted under the latch forend and under the latch keep
- Use of Intumescent gaskets supplied with door closers (as applicable)

### 2.7.1 Lockcases & Latches

The forend plate and keep must be protected with 1mm intumescent interdens for FD30 doors and 2mm intumescent interdens for FD60 doors.

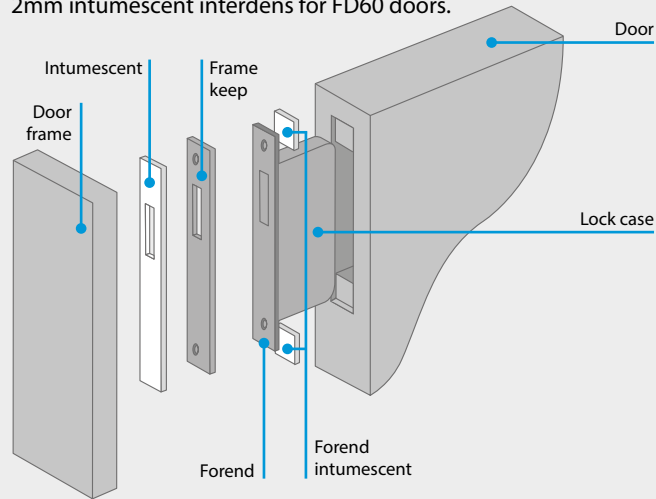

### 2.7.2 Flush Bolts

Flush bolts are incorporated centrally in the door thickness into the top and bottom of one meeting edge. The flush bolt should be fitted opposite the leaf that has the 20mm x 4mm intumescent. The maximum size of flush bolt permitted is; 200mm long x 20mm deep x 20mm wide.

Flush bolts must be steel and the mortice must be as tight to the mechanism as is compatible with its operation.

All edges of the mortice must be protected with the 0.8mm intumescent concealed three-sided kit.

Alternatively, the hardware manufacturer's tested gaskets may be used.

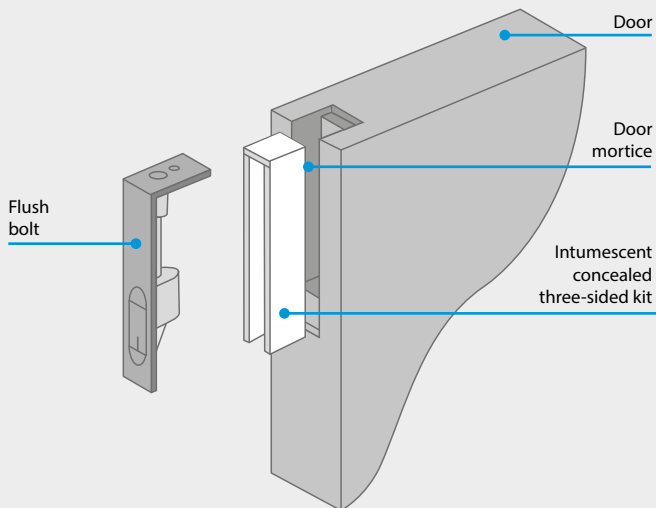

### 2.7.3 Concealed Automatic Closing

All sides of mortices for all components in the leaf and frame head, covering the entire top surface of the closer body and guide rail arm, must be protected with 1mm intumescent interdens for FD30 doors and 2mm intumescent interdens for FD60 doors.

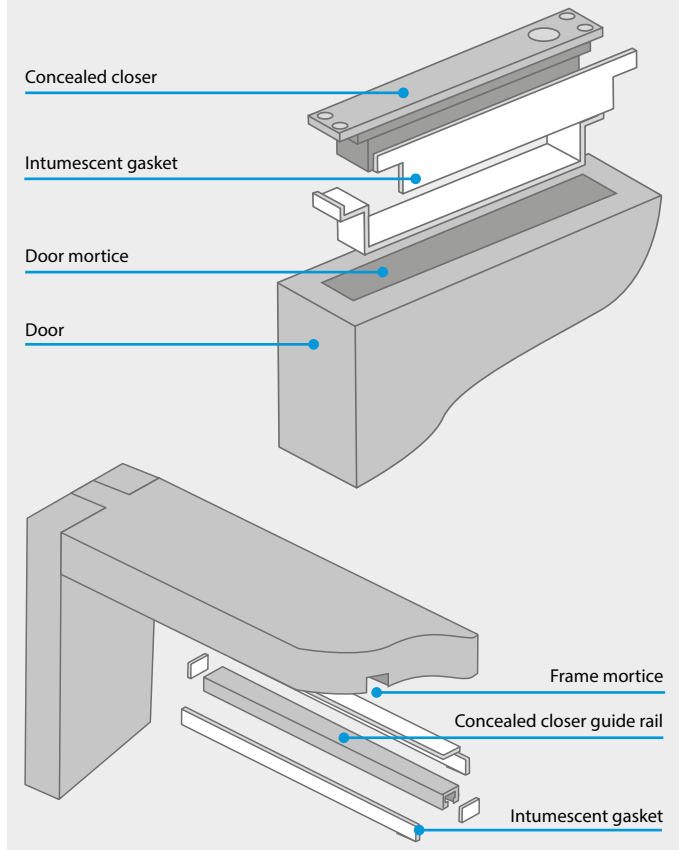

## 2.7.4 Pivots (top only)

All sides of mortises, of all the components in the leaf and frame head, must be protected with 1mm intumescent interdens for FD30 doors and 2mm intumescent interdens for FD60 doors.

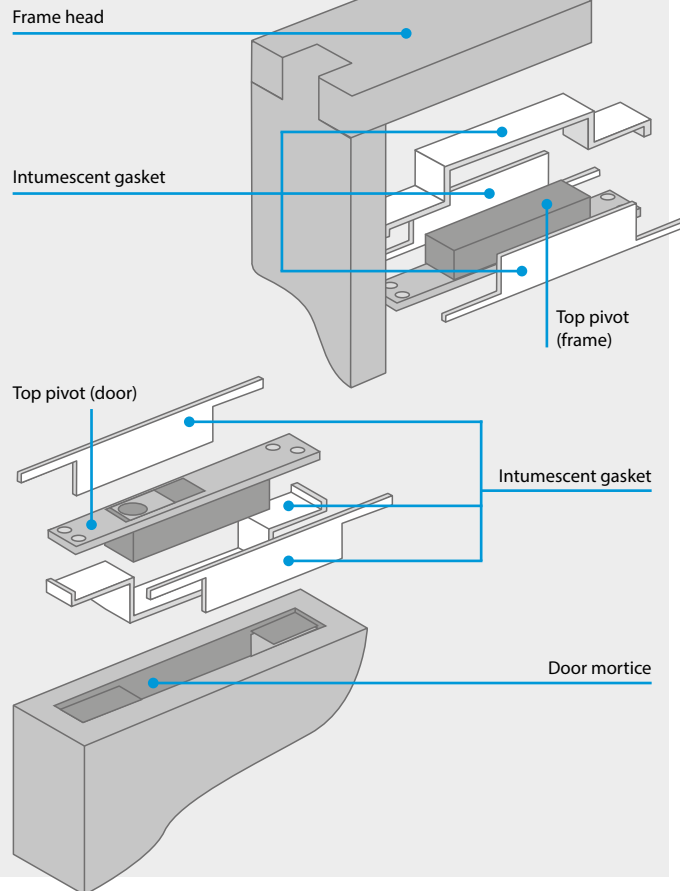

## 3.0 Fire Door Maintenance

Fire doors are intended to facilitate a similar level of fire resistance as per the structural elements of a building. However, since doors are often opened and closed many times a day, it is important therefore for regular inspection to be performed.

Fire door inspection should therefore be appropriate for the building; for high life risk buildings, such as hospitals, schools or retired persons' accommodation, this may be once per month, alternately buildings with low life risk may be every six months.

- Recommended clearance of 3mm (between door and frame) along head and down sides.
- Where applicable, any signs of damage to the glass or glazing system, as the glass and glazing system are critical to the performance of the fire door.
- Fire and smoke seals (as maybe fitted) for any signs of damage, degradation or missing in part or total, as either of these will have serious implications on the fire door performance.
- Hinges should be inspected for signs of wear. Worn hinges should be replaced with those that perform in accordance with the latest edition of BS EN 1935 and have corrosive test evidence in accordance with BS EN 1670.
- Ensure that (where fitted) the latch or lock furniture moves freely and engages fully. Damaged or badly worn latch or lock furniture should be replaced immediately.
- Self-closing devices should be examined to ensure it closes the door leaf properly. The door should close effectively from any angle.

There are a number of reasons why doors may fail to close:

- Check that there are no foreign bodies or other objects obstructing the door.
- Check that any smoke seals (as maybe fitted) remain correctly fitted and are undamaged.
- Check the latch (if fitted) to ensure correct operation.

Any self-closing device (as maybe fitted), which is unable to be effectively adjusted, should be replaced using a closer that has been

validated by test for use on a door assembly of similar specification, and performs in accordance with the latest edition of BS EN 1154.

It is not easy to repair doors and maintain the interactive behaviour of the various component parts. Minor repairs to a 30 minute fire rated door leaf, which Ahmarra recommend, are performed via a professional source. Door leaves providing a 60 minute fire rating or higher should be replaced, not repaired.

Please note: In the event of damage that necessitates the replacement of one leaf of a double door, both leaves should be replaced with a new matching pair.



## 3.1 Fire Door Decoration

Fire door leaves are generally not required to provide a specific surface spread-of-flame barrier, and may therefore be re-decorated as desired.

Whilst suggested that the over painting/varnishing intumescent seals does not have detrimental effects, it is recommended that such action is limited to a maximum of 5 coatings. Where intumescent seals are incorporated within the door frame the use of heat or chemicals in preparation for re-coating should be avoided.

Q-Mark certified fire doors supplied by Ahmarra are permanently marked with their declared fire resistance period by means of a colour-coded plug(s). It is therefore recommended to avoid painting over the plug(s) during redecoration.

### 3.2 Push Plates & Signage (Education Range only)

Where plates and signage are to be fitted, the diagram below provides suggested locations.

Push plates and signs will have been sent with the door delivery in a separate bag. Please check the door labels to ensure you fit the correct signs and plates to the door.

The 1620mm height applies to the fixing of the primary signage for the door. Any additional signs should be fixed as per the additional signage on the diagram (90mm centre to centre above the primary).

### 3.3 Care Advice

#### Appearance

As a natural material, hardwoods used for frames, lippings and beads can vary in colour from its equivalent veneer. Occasionally, lighter colour sapwood or resin pockets may be present - this is a natural feature and not a defect.

#### Veneers

Veneers should be lightly washed with a diluted liquid detergent applied with a sponge or soft cloth. Minor damage should be repaired by lightly sanding, using beeswax if required, and finally applying a semi-matt lacquer using a fine brush.

#### Laminates and PVC

Lightly wash with a diluted liquid detergent applied with a sponge or soft cloth. Minor damage or scratches should be filled with a special laminate filler available from laminate manufacturers.

#### Finish Primed

The initial coat of primer will tend to raise the grain of the timber and will require flattening on-site with a fine abrasive before further coats are applied.

#### Fully Painted

Factory applied paint is either water-based or AC lacquer and is highly resistant to most household chemicals, grease and solvents. Both are also resistant to minor abrasions. Lightly wash with a diluted liquid detergent applied with a sponge or soft cloth. Minor damage should be filled and painted with a matching BS/RAL colour satin finish paint.

#### Factory Lacquered

Lacquer is resistant to most household chemicals, grease and solvents and minor abrasions. Lightly wash with a diluted liquid detergent applied with a sponge or soft cloth.

#### Fire Door Operation

Dependant on the intended circumstance, the fire door can be fitted with a handle which can activate various locking mechanisms i.e. only the middle locking latch is engaged. To lock and unlock the door insert the door key and turn the key in the alternate direction for locking, then press down the door handle to release (disengage) the door locking points and then open the door.

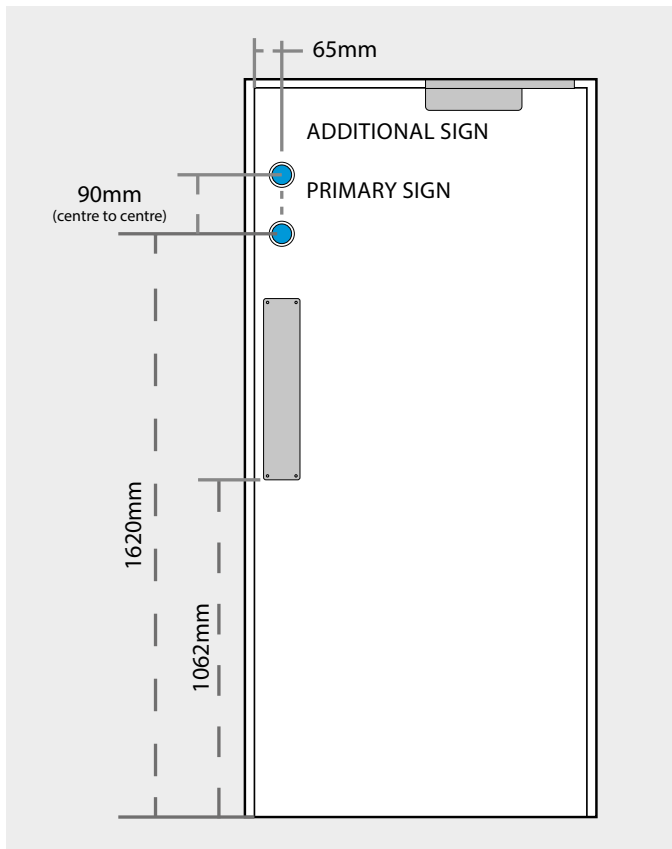

## Maintenance

Regular inspection should be carried out to ensure that doors are operating correctly and not binding on floors or against the lock keep, as this will cause damage to the door. It is particularly important to check that intumescent/smoke strips are undamaged.

### Loosening of Screw Fixings

Screw fixings may become loosened as a result of over-stressing. The cause should be remedied and any damage repaired immediately. Common causes include:

1. Absence of floor or wall-mounted doorstop or adequate restraint to the door, which can loosen hanging screws and may cause fracture of the door leaf if continually racked.
2. Excessive tension on closing devices and loss of damping effect to springs which can loosen hanging screws and closer fixings.

### Impact Causing Loosening of the Frame Fixings

The most common symptom of loosened hanging fixings is the leading edge of the door drooping and binding on the floor, or at meeting edges, or in the lock jamb of the frame. Take remedial action immediately.

## Repair and Trouble Shooting Techniques

If a screw position is over-drilled or fails to hold, use a longer screw wherever possible and certainly in connection with all hinge or pivot strap problems in 12 or 25mm increments.

Where longer screws cannot be employed, fill hole with Timber Fill and re-drill.

To re-fix lippings, repair splits, loose faces or veneer etc., glue and clamp, or pin as appropriate, using Rakolit adhesive.

### Ironmongery

**Please note:** Fire doorsets are designed with specific performance features and supplied with applicable ironmongery machined, and where appropriate, fitted. Absolutely no substitution, adjustments or additions are allowed to be made. On the very rare occasion where requirements may change, advice must be sought from Ahmarra.

### Door Furniture

Clean with a soft cloth, do not use any abrasive cleaners or metal polishers.

## Door Roller Catches

Door roller catches should be checked periodically that all fixing screws are secured.

When fixing ironmongery to new positions always pilot drill to full depth of screw using drill size as follows:

No. 6 screw: 1/16 drill

No. 8 screw: 5/64 drill

No. 10 screw: 3/32 drill

No. 12 screw: 1/8 drill

## Hinges

For hinge fixing use No 10 - 50mm screws for the door core and 30mm for the frame/lining. Do not over-tighten screws so as to strip thread in core. Never hammer screws in.

## Ironmongery

For face fixed ironmongery use the largest possible screw to suit ironmongery item.

Lever and knob handles should be of the type that does not rely on any screw fixing in the leaf.

## Modification

The doorset must not be modified in any way except for any modification allowed under the Field of Application, such as minor trimming of lippings. Any modifications carried out should be clearly documented.

Please note: Details within the installation section are for guidance purposes only; the contents have been extracted from our current test evidence for all installations.

For further advice, please contact Ahmarra directly.



## Cleaning Procedures

The cleaning of each ironmongery item will vary, however the following guidance is generally applicable:

- Avoid the use of harsh cleaners, or cleaning materials such as scouring sponges, as this may damage the item's finish
- Use appropriate protective equipment when using any detergents
- Clean with a mild detergent, warm water and rinse with clean water
- Dry with a soft cloth

## Storage

Ironmongery is carefully packed before delivery in order to avoid damage. Before fixing of the product, it should be stored in a secure, clean and dry location.

Abrasives, acids and other corrosive materials should be stored well away from hardware.

## Fixings

When products are supplied with appropriate fixings and fixing instructions, these should be used. The supplied fixings should not be substituted with others, as this may affect product performance. Fixing instructions should be retained and given to Building Maintenance staff for future reference.

## Installation

All ironmongery should be correctly installed in accordance with the supplied fixing instructions. After fitting the ironmongery, it should be carefully protected throughout construction.

## Hinges

The **monthly** maintenance procedures for hinges are:

- Check the tightness of fixings
- Apply a light machine oil to the hinge knuckle if required
- Wipe hinges clean

All hinges must be adequate for purpose and fitted accurately, so that all hinge pins are in vertical alignment.

Hinges are usually supplied dry by the manufacturer, and should be lubricated immediately after installation. However, typically in the case of ball bearing type hinges, the manufacturer will insert some grease/lubricant at the time of production.

The recommendation is, as part of a building maintenance programme, that the hinges be checked, cleaned and lubricated periodically with a light machine oil (e.g. 3-in-1 oil), to maintain the hinge's efficiency, aesthetic and to prolong its life.

It is normal that some oil residue may seep through the knuckle joints. The grease can be cleaned easily using warm soapy water, or a lint free cloth with a small spray of silicone oil, WD40 or GT85. If the oil is not cleaned off, dust and other contaminants will stick to it.

The below images show a hinge with a residual oil around the knuckle joint (left), and then the same hinge following a quick wipe with warm soapy water (right).



There are certain circumstances where hinges require a specialist dry film lubricant. Such circumstances would include when doors are situated in dusty locations, where a mixture of oil and grit can act as a grinding paste. Or when doors are situated in public toilet/wet room areas, which are subject to hosing down or washing with detergent, that would remove standard oil.

Hinges should be checked regularly for wear, loose screws etc. Squeaking hinges are a sign of lack of lubrication, but frequent occurrence is a sign of misalignment, and should be rectified immediately.

Failure to fix hinges correctly, or if maintained inappropriately, could lead to invalidation of the manufacturer's guarantee.

## Lever Handles and Knobs

The suggested **monthly** maintenance procedures are:

- Check the tightness of fixings and that handles are secure
- Check the lever or knob fully retracts the latch
- Lubricate moving parts, as required, with a light machine oil
- Tighten grub screw and spindle fixings as required - or if missing - replace them

## Master Keyed Cylinders

The suggested **quarterly** maintenance procedures are:

Wipe clean as directed in the 'Care of Finishes' section

- Only lubricate where necessary, and only with manufacturer approved cylinder spray or graphite
- Do not use a silicone-based lubricant, which may cause the cylinder to fail

## Locks and Latches

The suggested **quarterly** maintenance procedures are:

- Check the tightness of fixings on the strike plates/forends
- Clean with a mild detergent, warm water and rinse with water
- Dry with a soft cloth
- Ensure latch bolts are free from dirt or debris
- Lubricate latch bolts, as required, with a light machine oil or suitable lubricant for that lockcase

The correct operation of a lock or latch, if it has been fitted correctly, is often affected by the movement of the door and/or frame occurring, which can be due to distortion influenced by climatic conditions or wear on hinges or pivots, causing the door to drop.

The effect is usually an inability of the latch and deadbolts to easily engage the strike plate or keep. Therefore, an adjustment to their position on the frame, or an adjustment to the lip of the strike plate, may be necessary to provide a more favourable striking angle.

Pin tumbler and disc cylinders should be lubricated with either flake graphite or PTFE lubricant.



## Overhead Door Closers

The suggested **quarterly** maintenance procedures for overhead closers are:

- Ensure the door closes fully from the open position
- Ensure the door latches fully into the striking plate where relevant
- Check the tightness of fixings
- Clean with a mild detergent, warm water and rinse with clean water
- Dry with a soft cloth
- Remove foreign material from the moving parts at the bracket and arm knuckle
- Apply a light machine oil to the moving parts at the bracket and arm knuckle

All door closers must be adequate for the purpose and must be fitted in accordance with the manufacturer's instructions.

All overhead door closers supplied by Ahmarra are compliant with BS EN 1154 and BS EN 1155 standards. The door closer, once fitted, must be commissioned properly for use. Failure to comply could lead to invalidation of the manufacturer's guarantee.

Only cleaning agents not containing corrosive and damaging components should be used.

It is also recommended that doorstops be fitted, where practicable, to all doors with door closers, even if there is a backcheck within the closer.

## Electro-Magnetic Closers

The suggested maintenance procedures for electro-magnetic closers are as per overhead door closers (above), but in addition:

- Any electrical and point hold-open devices must be checked on a **weekly** basis.

## Floor Springs

The suggested **quarterly** maintenance procedures are:

- Ensure the door closes fully from the open position
- Ensure the door latches fully into the striking plate where relevant
- Check the tightness of fixings
- Clean with a mild detergent, warm water and rinse with clean water
- Dry with a soft cloth
- Remove foreign material from the moving parts and pivot points

The floor spring must be of a type suitable for the door application it is fitted to, ensuring that there is no strain on the mechanical parts. If in doubt, please refer to BS EN 1154/5 for details.

The floor spring must be fitted in accordance with the manufacturer's instructions, and the pivot centres must be perfectly vertical.

## Kicking Plates and Push Plates

The suggested **quarterly** maintenance procedures are:

- Wipe clean as directed in the 'Care of Finishes' section
- Check the tightness of fixings

## Panic and Emergency Exit Hardware

The suggested **weekly** maintenance procedures are:

- Check for debris in floor sockets
- Check that all units are lubricated and secure

Exit hardware should be fitted according to the manufacturer's instructions and must comply with BS EN 179 (emergency) or BS EN 1125 (panic exit). Failure to do this could mean that the device will not be covered by the manufacturer's guarantee or work correctly.

## Care of Finishes

Because most surface coatings are applied by complex high volume production processes, it is not usually possible to reproduce the finishing conditions outside of the factory. Therefore, for long-term durability of a finish, prevention of unnecessary corrosion is better than attempting a cure.

Atmospheric deposits of dust and grime are the major causes of premature deterioration of the surface coatings, because of the wide variety of chemical pollutants in the atmosphere. When such chemicals become damp, they often initiate local attack, generally in the form of pitting on the surface finish. Dampness can rarely be prevented, but dust and grime can usually be removed by dusting with a dry cloth or by washing neglected surfaces with clean or soapy water. Little and often should be the rule, avoiding the use of even the mildest abrasives. The application of wax or silicone polishes can also be beneficial because of the barrier layer created between surface finish and atmospheric deposits.

### Satin Stainless Steel - SSS

- Clean regularly with detergent and warm water
- Dry with a soft cloth
- Do not use abrasive cleaning materials

### Polished Stainless Steel - PSS

- Clean regularly with detergent and warm water
- Dry with a soft cloth
- Do not use abrasive cleaning materials

### Anodised Aluminium - SAA or PAA

- Clean regularly with detergent and warm water
- Dry with a soft cloth
- Do not use abrasive cleaning materials

### Bronze - BZ

- Bronze finishes should be dusted regularly and periodically washed in warm soapy water
- They should also be treated occasionally with a sparing rub of wax or furniture polish

### Brass - PB

- Clean regularly with detergent and warm water
- Dry with a soft cloth
- Do not use abrasive cleaning materials

### Lacquered Brass - LB

- Lacquered brass finishes should be cleaned by the occasional application of a light coating of wax polish
- Eventually it is likely that the lacquer will become damaged and break down. When this occurs, all traces of the lacquer should be removed using acetate lacquer remover. The product may then be re-lacquered or cleaned as un-lacquered brass on a regular basis
- The application of wax polish once a week is recommended
- Abrasives and metal polishes should not be used

### Unlacquered Brass - UB

- Natural unlacquered brass should be polished from time to time with a proprietary brass cleaner or left to acquire the natural patina of brass over a period
- Surface grease and dirt can be wiped off using soapy water and a soft cloth, and a light coating of furniture wax applied

### Nylon/Polyamide - NY

- Clean regularly with detergent and warm water
- Only use detergents with a Ph balance between 6 and 8
- Detergents containing active substances such as phosphates, soap and tensides may be used
- Do not use detergents containing acids, alkalis, bleach or scouring agents
- Dry with a soft cloth

### Nickel and Chrome - NIC

- Door furniture with nickel and chrome finishes should be dusted regularly
- They should be washed periodically with a weak detergent solution, and rubbed occasionally with a cloth dampened in paraffin or light oil

### Electro Plated - EP

- Electrophoretic and plated finishes should be wiped clean with soapy water and a soft cloth, and then wiped dry

### Powder Coated - PC

- Epoxy, polyester or polyurethane powder coated finishes should be cleaned with a soft cloth and household furniture polish
- Under no circumstances must industrial solvents be used

### Stove Enamelled - SE

- Stove enamelled finishes should be wiped with a non-abrasive, soft cloth and a gentle cleaner

### PVD (Physical Vapour Deposition) - PVD

- PVD should be wiped with a soft cloth that is damp, or use with a general furniture polish



ahmarra

T 02392 389 076  
E [aftersales@ahmarra.co.uk](mailto:aftersales@ahmarra.co.uk)  
W [www.ahmarra.co.uk](http://www.ahmarra.co.uk)

Unit 2 Hermitage Park,  
Harts Farm Way, Havant,  
Hampshire PO9 1FA